

A CPU Cooler
CPU Kühler
Ventirad
CPU 쿨러 (방열기)
CPU散热器

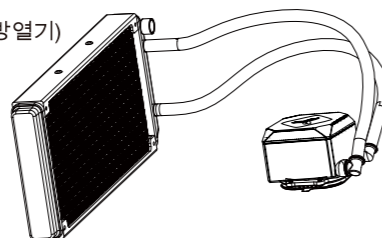
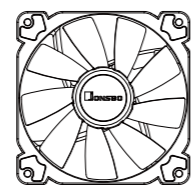

B Fan
Ventilator
Ventilateur
팬 (FAN)
风扇

 X3

C Backplate
Backplate
Contre Plaqué
백플레이트
背板

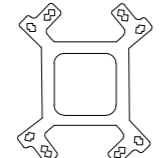

D Intel Bracket
Intel Halterung
Intel Bracket
인텔 브래킷
英特尔支架

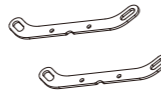

E AMD Bracket
AMD Halterung
AMD Bracket
AMD 브래킷
AMD支架



F Thermal Paste
Wärmeleitpaste
Pâte thermique
써멀 페이스트
散热膏

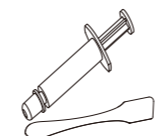

G1 Screw
Schraube
Vis
나사
螺丝 x4



G2 x4 BACKPLATE SCREWS
115X底板螺杆



G2-1 x4 BACKPLATE SCREWS
1700底板螺杆



G3 x4



G4 x4



G5 x4



G6 x4





G7 x12

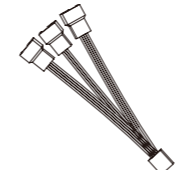

H Y-Cable
Y-Kabel
Câble en Y
Y- 케이블선
Y-转接线

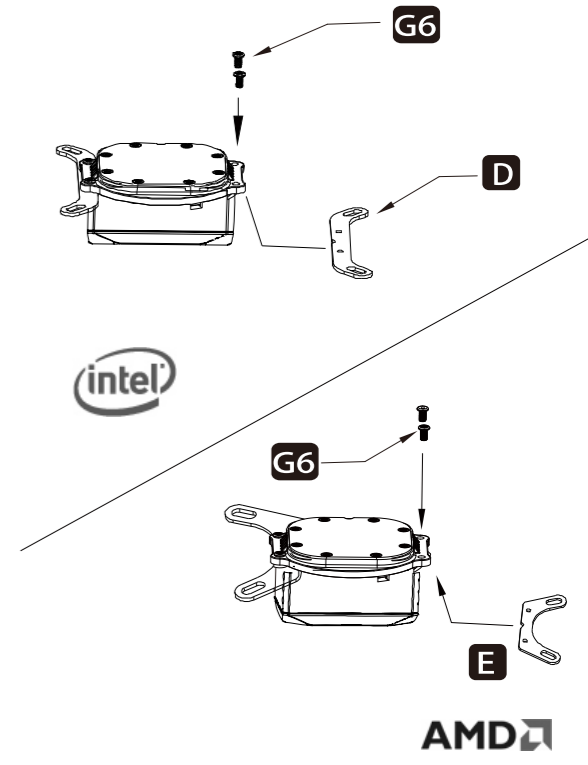
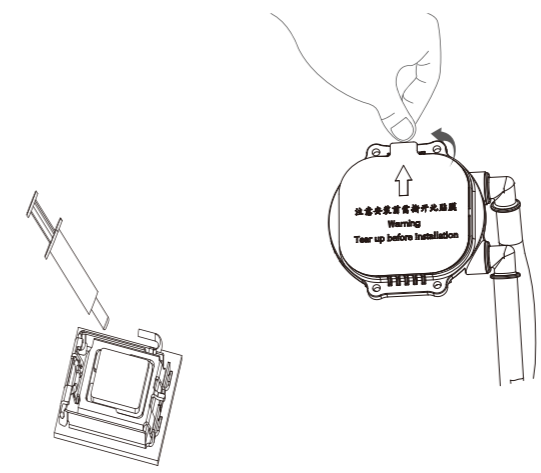

G8 x4



Applying thermal paste / Remove the protection film
Aufbringen der wärmeleitpaste / Entfernen Sie die Schutzfolie
Application de la pâte thermique / Retirez le film protecteur
방열 써멀구리스를 바르고 / 보호막을 뜯어 주세요
涂抹散热膏 / 取下保护膜

Installing the Intel / AMD bracket
Installieren der Intel / AMD-Halterung
Installation du bracket Intel / AMD
Intel 설치 / AMD 지지대
安装Intel / AMD支架

© 2017 JONSBO SHENZHEN TECHNOLOGY CO., LTD. All right reserved. Specifications are subject to change without prior notice. Some trademark may be claimed as the property of others.

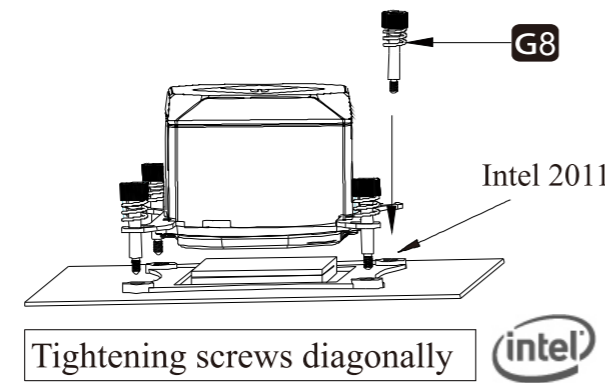
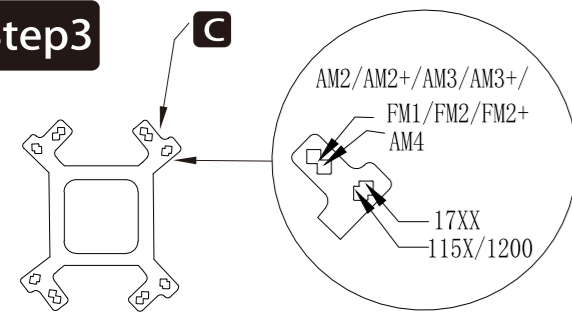

Secure the cooler -Intel LGA 2011
Den Kühler sichern -Intel LGA 2011
Fixez la glacière -Intel LGA 2011
고정 쿨러 (방열기) - Intel LGA 2011
固定散热器 -Intel LGA 2011

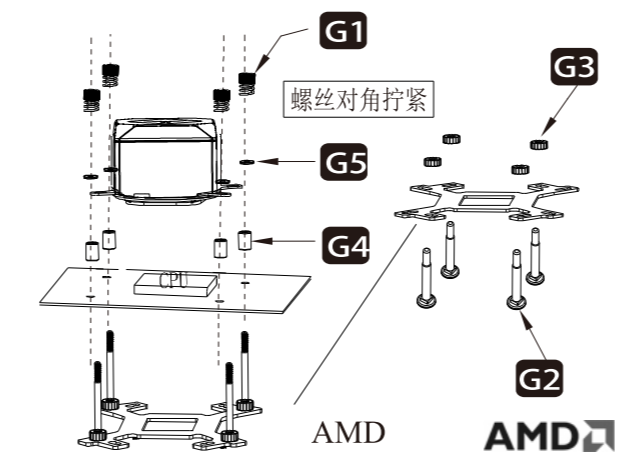
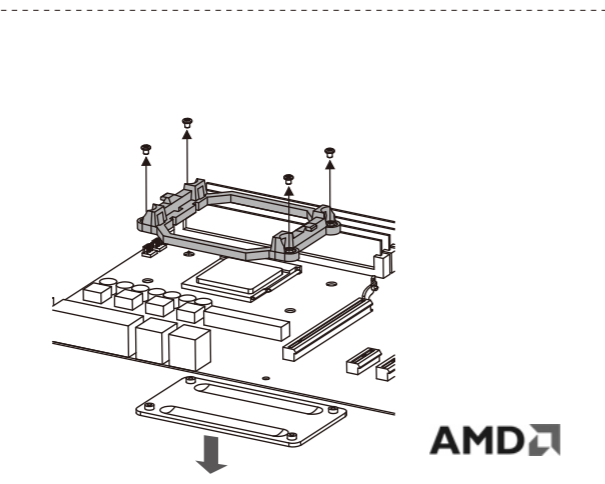
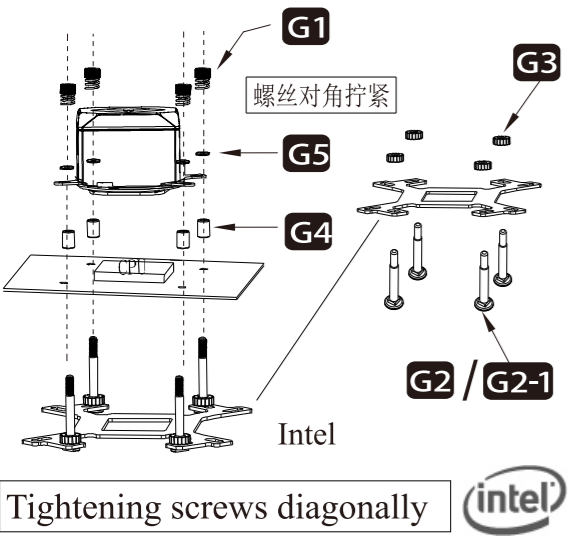

Secure the cooler -Intel LGA 115X/1200/1700
Den Kühler sichern -Intel LGA 115X/1200/1700
Fixez la glacière -Intel LGA 115X/1200/1700
고정 쿨러 (방열기) - Intel LGA 115X/1200/1700
固定散热器 -Intel LGA 115X/1200/1700

Remove the plastic retainers of the AMD retention module
Bitte entfernen Sie die Kunststoffhalter des AMD-Retentionsmoduls.
Veuillez retirer le dispositifs de retenue en plastique du module de rétention AMD.
AMD의 고정 쿨러 모듈을 떼어 주세요
卸下AMD的散热器固定模式

Secure the cooler -AMD
Den Kühler sichern -AMD
Fixez la glacière -AMD
고정 쿨러 (방열기) - AMD
固定散热器 -AMD



Connect the 3-pin connector from the pump unit to AIO/PUMP socket on the motherboard
Verbinden Sie den 3-poligen Stecker der Pumpeneinheit mit der AIO / PUMP-Buchse auf der Hauptplatine
Connectez le connecteur à 3 broches de la pompe à la prise AIO / PUMP de la carte mère
3PIN 커넥터를 메인보드 AIO/PUMP 콘센트에 연결해 주세요
冷头上3PIN接口连接至主板AIO/PUMP插针

Connect the 4-pin connector of the PWM fan with a Y-cable to the CPU_FAN socket on the motherboard
Verbinden Sie den 4-poligen Stecker vom PWM-Lüfter mit einem Y-Kabel mit der CPU_FAN-Buchse auf dem Motherboard
Connectez le connecteur à 4 broches du ventilateur PWM avec un câble Y à la prise CPU_FAN sur la carte mère
PWM의 4-PIN 커넥터를 Y-케이블을 통해 메인보드 CPU_FAN 콘센트에 연결해 주세요
风扇4PIN PWM供电线通过Y线连接至主板CPU_FAN插针

1 Connect to ASUS's 5V AURA socket
Schließen Sie die 5-V-AURA-Buchse von ASUS an
Connectez-vous à la prise AURA 5V d'ASUS
ASUS(아수스) 5V AURA 콘센트에 연결해 주세요
连接至华硕5V AURA接口

2 Connect to GIGABYTE's 5V VDG socket
Schließen Sie die 5-V-VDG-Buchse von GIGABYTE an
Connectez-vous à la prise VDG 5V de GIGABYTE
GIGABYTE(기가바이트) 5V VDG 콘센트에 연결해 주세요
连接至技嘉5V VDG接口

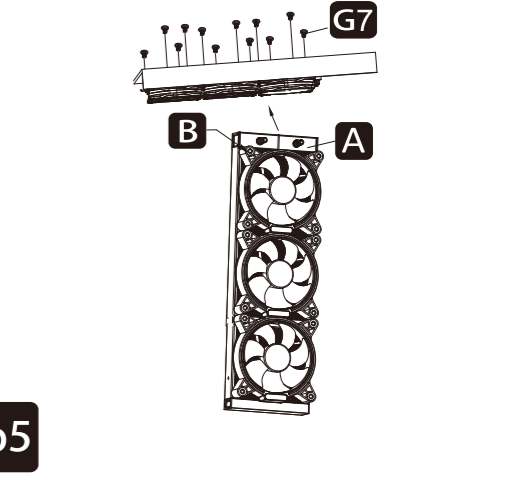
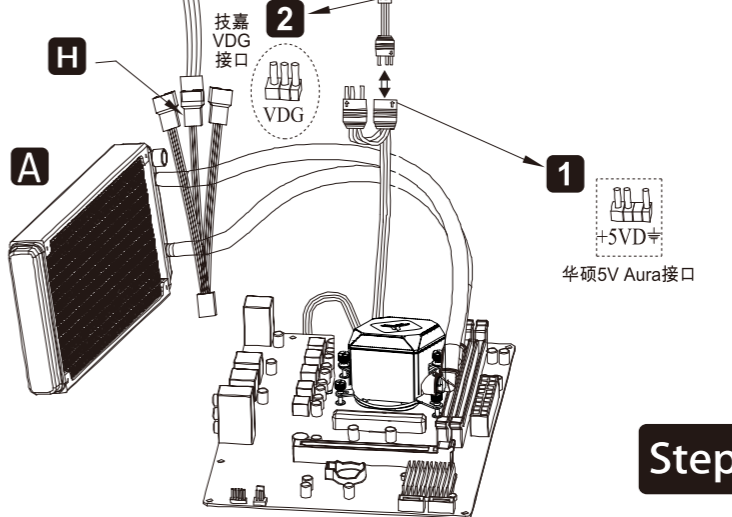

Connect fan and pump cables to CPU_fan & AIO/PUMP/SYS_FAN sockets
Schließen Sie die Lüfter- und Pumpenkabel an die Buchsen CPU_fan & AIO / PUMP / SYS_FAN an
Connectez les câbles du ventilateur et de la pompe aux prises CPU_fan et AIO / PUMP / SYS_FAN
FAN과 PUMP 케이블을 CPU_FAN & AIO/ PUMP/ SYS_FAN 콘센트에 연결해 주세요
将风扇和冷头电缆连接到CPU_FAN&AIO/PUMP/SYS_FAN插槽

Secure the the fans and radiator
Lüfter und Kühler sichern
Ventilateur et refroidisseur sécurisés
고정 팬(FAN) 및 라디에이터(Radiator)
固定冷排至机箱