

T02

侧板玻璃
Tempered glass
side plate

顶部PVC磁性防尘网
Top plate PVC magnetic filter

右侧板
Right side plate

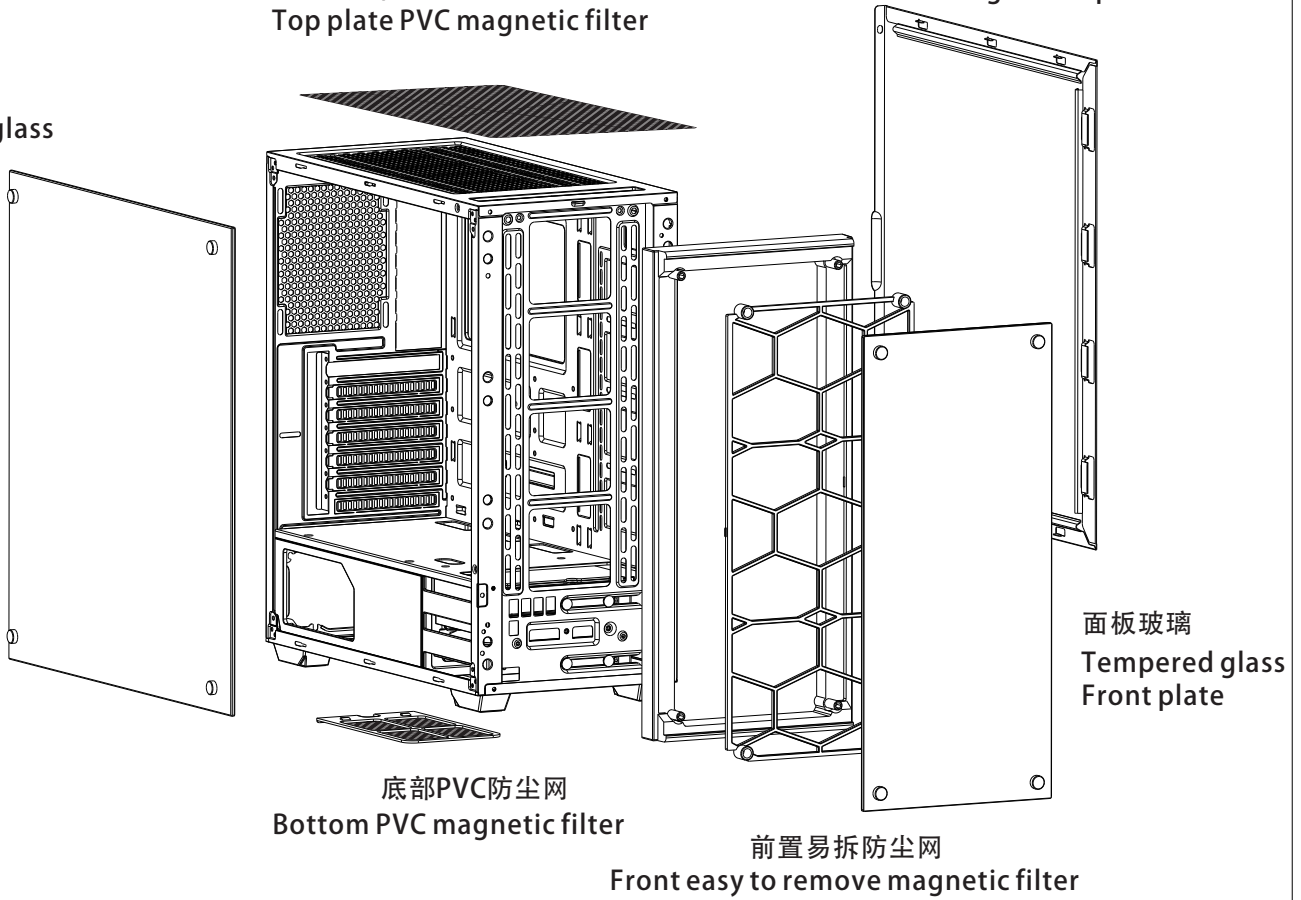

Figure	Parts Name	Q'ty	Used for
	Standoff M3/ M4 6.0 mm	6	Motherboard
	Standoff M3/ #6-32 5.0 mm	1	Fixed glass
	Screw #6-32 6 mm	4	Power Supply
	Screw #6-32 6 mm	5	Graphics card
	Screw #6-32 4 mm	4	3.5"HDD
	Screw M3 5 mm	12	Motherboard
	Screw #6-32 28 mm	2	FANS
	Screw #6-32 6 mm	6	3.5"HDD
	Movable tie	3	Cable Management

组装步骤
Assembly steps

1

把机箱平放松开4颗螺丝取下左右侧板

Lay down the case, remove 4 screws and take out left/right side plate

2

装入I/O弹片，再装入主板用螺丝锁固

Install I/O plate, then install motherboard and lock with screws

3

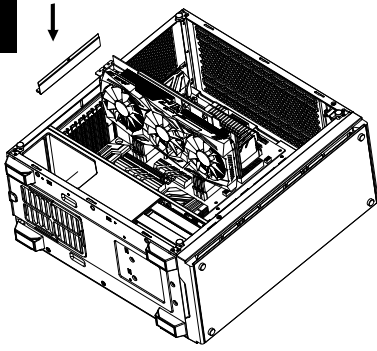

松开PCI螺丝, 取下
PCI卡条,再装入显卡

Loosen PCI screws,
take out PCI slot
plate and then
install Video card

4

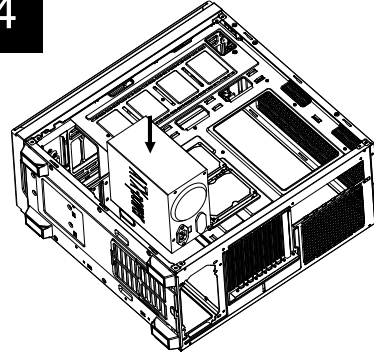

把机箱放平,
装入电源

Lay down the case,
install PSU

5

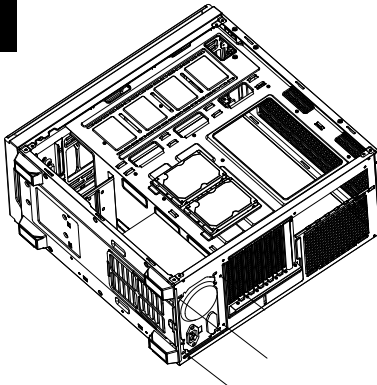

锁上电源4个螺丝

Lock PSU with 4
screws

6

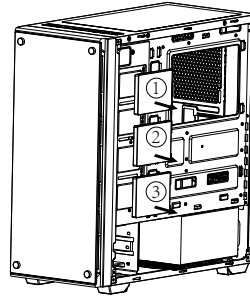

背部支持安装

3 x 2.5 SSD

7

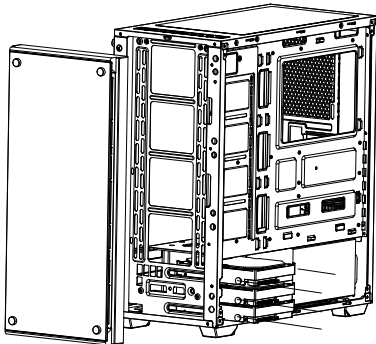

3 x 3.5 HDD

8

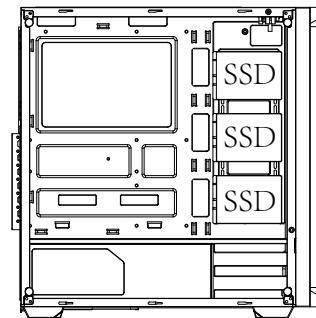

支持安装

3 x 2.5 SSD

9

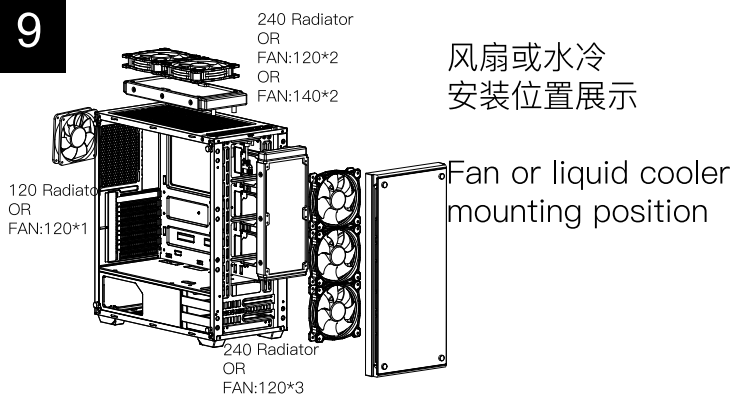

风扇或水冷
安装位置展示

Fan or liquid cooler
mounting position

240 Radiator
OR
FAN:120*2
OR
FAN:140*2

120 Radiator
OR
FAN:120*1

240 Radiator
OR
FAN:120*3

10

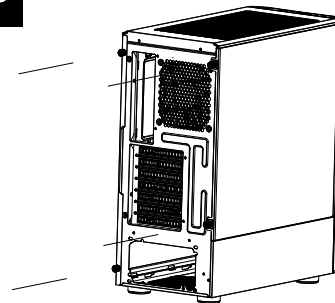

最后装上左右侧板,
组装OK

Finally install left/
right side plate,
assembly complete